

TAIPAN 365 ELECTRONIC CONTROL UNIT

INOX

Stainless Steel



- ✓ **MAXIMUM PRECISION**
- ✓ **UP TO 4000 dm³/h**
- ✓ **OFF CENTER LOAD CELL**
- ✓ **TWIN SCREW AVAILABILITY**

The type DPC dosers are indicated in the dosing of powders with medium flow rates. The batchers comprise a storage hopper, a feed device and a scale that controls decreasing weight during product discharge. Each type of batcher is available with a broad range of motor drives and in customized versions to suit the process. When the scale is combined with suitable electronics, the batcher can operate in batching and/or continuous mode with controlled feed rate. In the latter mode, hopper refill is controlled by electronics with no need to interrupt the batching process.

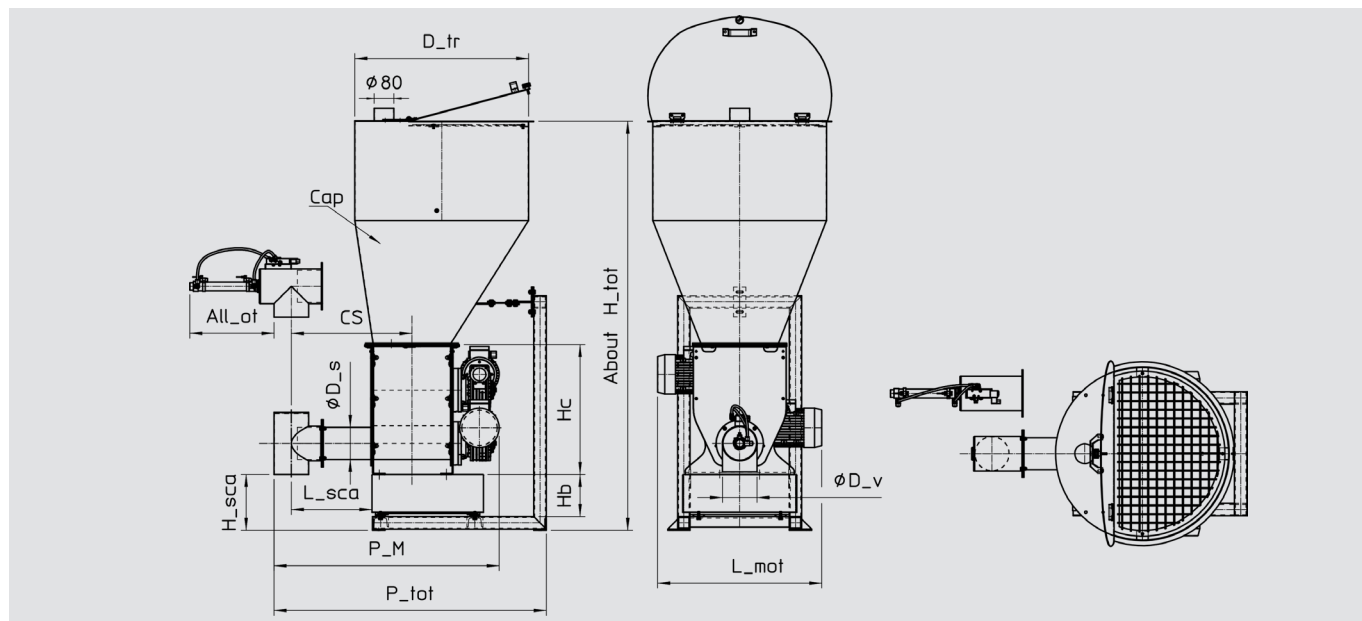

STANDARD MODELS DIMENSIONS (mm)

	Cap (dm ³)	P _{tot}	L _{mot}	H _{tot}	H _{sca}	D _{tr}	D _v	All _{ot}	D _s
DPC 020	60	705	480	980	220	600	42.4	130	27
DPC 030	110	740	600	1190	205	600	48.3	170	38
DPC 040	110	740	600	1190	205	600	60.3	180	45
DPC 060	200	1030	570	1500	180	700	88.9	200	70
DPC 080	200	1030	570	1500	160	700	114.3	220	90
DPC 100	200	1100	660	1650	225	700	139.7	340	129
DPC 20+20 (twin screw)	60	705	480	980	205	600	60.3	170	60
DPC 30+30 (twin screw)	200	970	570	1500	200	700	88.9	200	90
DPC 40+40 (twin screw)	110	950	570	1300	205	700	88.9	200	90
DPC 60+60 (twin screw)	200	1165	700	1600	145	700	168.3	280	150

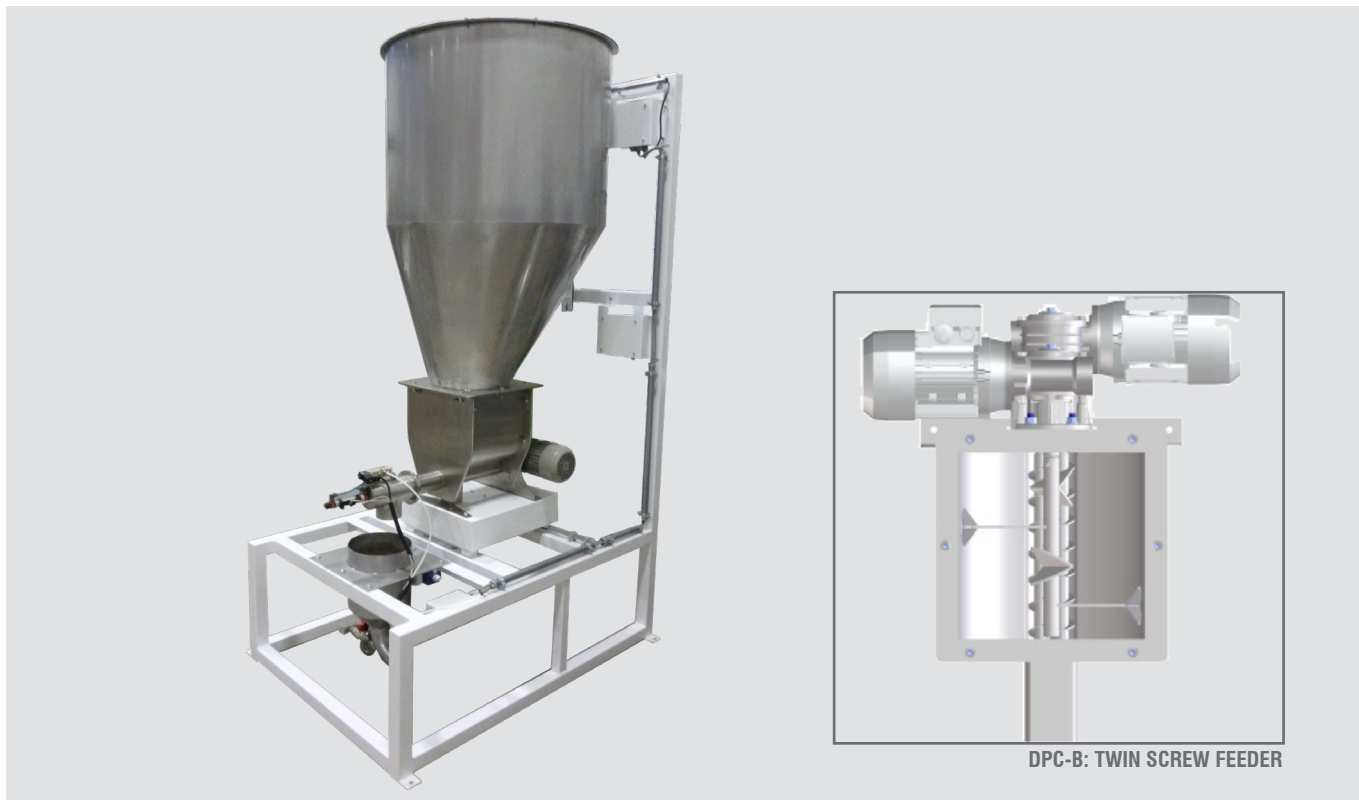

DPC-B: TWIN SCREW FEEDER

REFERENCE NOMINAL CAPACITY VALUES dm³/h

FEEDER MODEL	SINGLE SCREW (DPC)		TWIN SCREW (DPC-B)	
	MIN	MAX	MIN	MAX
DPC 020	4	25	• 7	45
DPC 030	20	90	• 35	150
DPC 040	60	200	• 100	350
DPC 060	150	600	• 260	1000
DPC 080	500	2000		
DPC 100	1500	4000		

TECHNICAL FEATURES

Main structure	Carbon steel
Body material	Stainless steel
Breaker motor	Asynchronous three-phase multi-voltage
Dosing motor	Asynchronous three-phase multi-voltage or brushless (optional)
Dosing screw	Many versions depending on the application
Charging hopper	Stainless steel
Weighing system	Single off-center load cells C3
Electronic control unit	TAIPAN 365
Electrical junction boxes	Available for load cells
Motor fan	Optional depending on the application
Vertical spout	With polycarbonate indicator
ATEX conformity	Available as an option for ATEX 22 zones

