

# WBE

## WEIGHING BELT WBE SERIES

# STAD



Made in Italy

**HIGH PRECISION**

**UP TO 80 t/h**

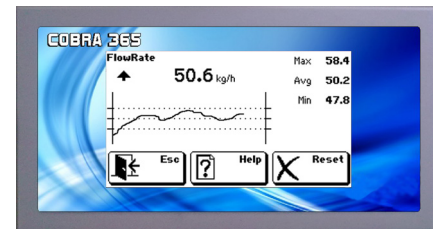

COBRA 365 ELECTRONIC CONTROL UNIT

The sturdy framework of the weighing belt of the heavy duty series, optimised for the installation under a hopper or silos, becomes a belt of the WBE series.

The weighing belt series WBP is suitable for dispensing heavy and big-sized material, as it is very sturdy. It has an operating capacity between 3 and 80 t/h approximately.

The belt can be made either with flat roller stations or triple roller stations. It can also be customized according to the weighed product.

COBRA 365 control unit allows its use as weight totalizer and, if combined to the extracting belt, as fixed capacity dispenser.

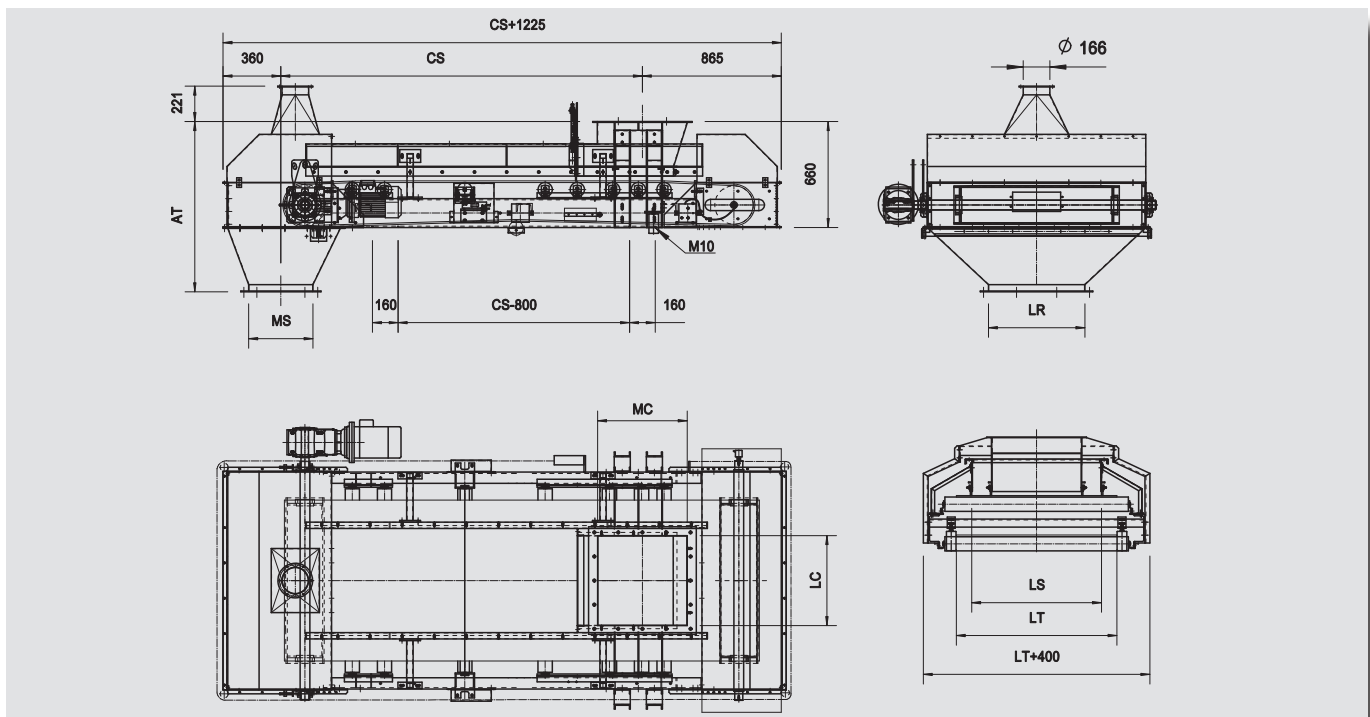

**STANDARD MODELS DIMENSIONS (mm)**

	LT	LS	CS	AT	LC	MC	LR	MS
<b>WBE 500</b>	500	350	1700	1060	250	250	300	250
<b>WBE 650</b>	650	500	1800	1060	350	350	350	350
<b>WBE 800</b>	800	650	1900	1060	500	500	400	400
<b>WBE 1000</b>	1000	800	2000	1060	560	560	600	600

Rev. 02 del 06/05/2016

**REFERENCE MAXIMUM CAPACITY VALUES**

Reference maximum capacity values specified below refer to the metering of material with small grain size and specific weight equal to 1 kg/dm<sup>3</sup>.

According to used motor drive, the allowed working range varies from 5 to 15 times.

BELT MODEL	SPECIFIC WEIGHT (kg/dm <sup>3</sup> )	MAX FLOW RATE (kg/h)
<b>WBE 500</b>	1.0	15.000
<b>WBE 650</b>	1.0	22.000
<b>WBE 800</b>	1.0	50.000
<b>WBE 1000</b>	1.0	70.000
<b>WBE 1200</b>	1.0	80.000

**TECHNICAL FEATURES**

Main structure	Carbon steel
Heads	Carbon steel
Loading and unloading hoppers	Carbon steel + HARDOX (optional)
Belt	Calibrated junction in various materials depending on the application
Side rails	Steel and soft bands depending on the application (optional)
Hood	Steel (optional)
Weighing system	Double off-center load cells C3
Speed control	Incremental encoder 1000 pulses/round IP67
Electrical junction boxes	Available for load cells and encoder IP66
Motor	Asynchronous three-phase multi-voltage
Motor fan	Optional depending on the application
Anti-vibration mounts	Steel and rubber 60ShA
ATEX conformity	Available as an option for ATEX 22 zones

